

NOT FOR CONSTRUCTION

CONCEPT

DAVENPORT
 HOME OFFICE: SUITE 2A
 305 WEST WASHINGTON STREET
 WINSTON-SALEM, NC 27101
 336.744.1535 www.davenportnc.com
 NCBELS FRM LICENSE NO. C3322



PROJECT:	13-333	SCALE:	AS NOTED
DATE:	07/07/16	DESIGNED BY:	JGT
DRAWN BY:	JGT	CHECKED BY:	JGT

NO.	DATE	DESCRIPTION

CLIENT:
WYTHE COUNTY
 340 S 6TH STREET
 WYTHEVILLE, VA 24382
 P: (276) 223-4500

PROJECT:
PROGRESS PARK CONNECTOR

TITLE:
TYPICAL SECTIONS

SHEET NO.
TS-01

-L1- PROGRESS PARK CONNECTOR

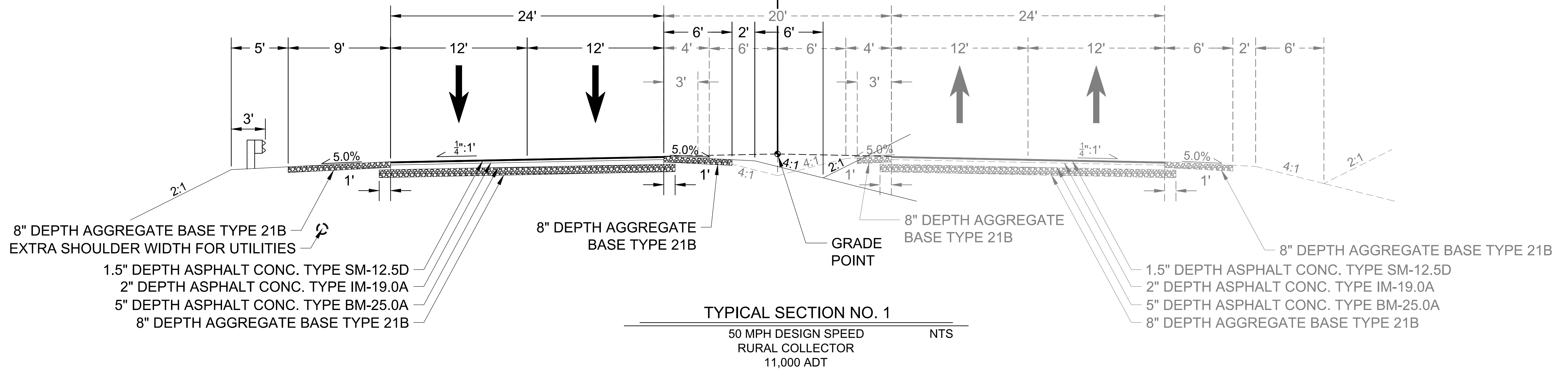

TYPICAL SECTION NO. 1

50 MPH DESIGN SPEED
 RURAL COLLECTOR
 11,000 ADT

-L1- PROGRESS PARK CONNECTOR

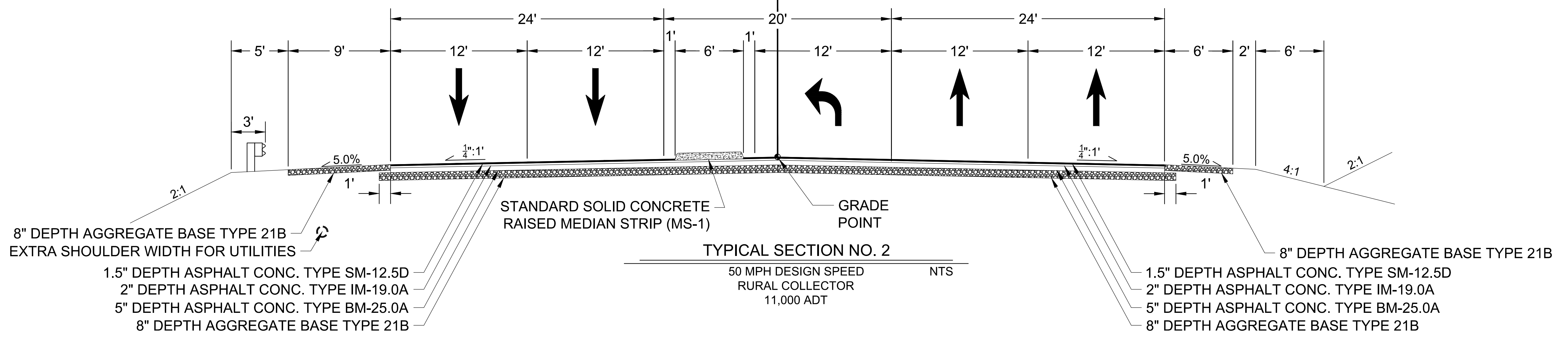

TYPICAL SECTION NO. 2

50 MPH DESIGN SPEED
 RURAL COLLECTOR
 11,000 ADT

130333_PPC_ZLANE.dwg 3/19/2007